

COMPUTED PROPERTIES, AS DESIGNED

AREA PER PILE - 7.314 SQ. IN.  
 AREA PER FOOT OF WALL - 3.523 SQ. IN.  
 LAYING WIDTH - 24.91 IN.  
 WEIGHT PER FOOT OF PILE - 24.470 LBS.  
 WEIGHT PER SQ. FOOT OF WALL - 11.788 LBS.  
 WALL DEPTH - 4.53 IN.  
 MATERIAL THICKNESS - 0.239 IN.  
 MOMENT OF INERTIA PER PILE - 24.590 IN.<sup>4</sup>  
 MOMENT OF INERTIA PER FOOT OF WALL - 11.846 IN.<sup>4</sup>  
 SECTION MODULUS PER PILE - 10.820 IN.<sup>3</sup>  
 SECTION MODULUS PER FOOT OF WALL - 5.212 IN.<sup>3</sup>  
 SHEET SECTION PERIMETER - 61.814 IN.  
 C/G TO OUTER FIBER - Y = 2.272 IN.

COATING AREA - SQ.FT.PER LIN.FT.OF PILE  
 FOR DIP COATING - 5.15 SQ.FT.  
 FOR SPRAY COATING - 4.87 SQ.FT.

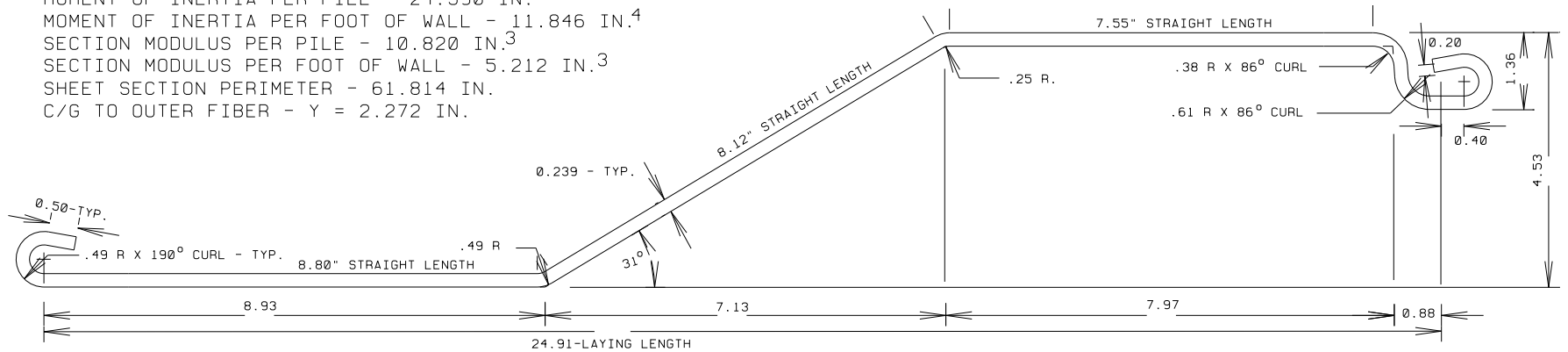

ROLL FROM 3 GA. (.239") STRIP APPROX. 30.1" WIDE

DRAWING		LZ 3 - NEW STYLE SHEET	
PROJECT		SHORELINE STEEL SUPPLY, INC.	
SCALE	FULL SIZE	DRAWING DATE	5 DECEMBER 1994
DRAWN BY	J.C.B.	LAST REV. DATE	
GENERAL MARINE SERVICE CORPORATION 22594 ARDMORE PARK DRIVE ST. CLAIR SHORES, MI 48081-2011 586-777-0945			94-1210
			DRAWING NUMBER