

COMPUTED PROPERTIES, AS DESIGNED

AREA PER PILE - 6.412 SQ. IN.
 AREA PER FOOT OF WALL - 3.085 SQ. IN.
 LAYING WIDTH - 24.94 IN.
 WEIGHT PER FOOT OF PILE - 21.410 LBS.
 WEIGHT PER SQ. FOOT OF WALL - 10.302 LBS.
 WALL DEPTH - 4.50 IN.
 MATERIAL THICKNESS - 0.209 IN.
 MOMENT OF INERTIA PER PILE - 21.520 IN.⁴
 MOMENT OF INERTIA PER FOOT OF WALL - 10.354 IN.⁴
 SECTION MODULUS PER PILE - 9.520 IN.³
 SECTION MODULUS PER FOOT OF WALL - 4.581 IN.³
 SHEET SECTION PERIMETER - 61.781 IN.
 C/G TO OUTER FIBER - Y = 2.259 IN.

COATING AREA - SQ.FT.PER LIN.FT.OF PILE
 FOR DIP COATING - 5.15 SQ.FT.
 FOR SPRAY COATING - 4.86 SQ.FT.

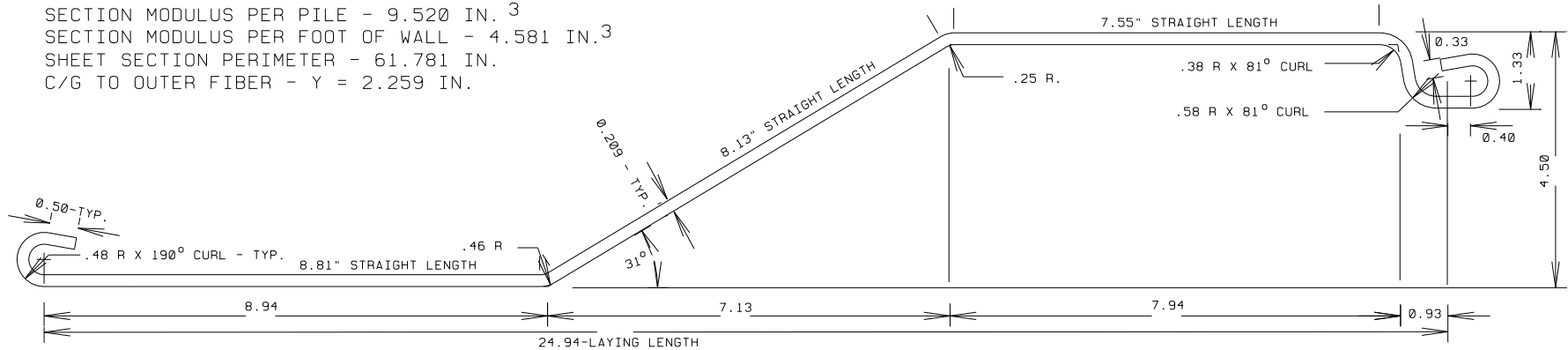

ROLL FROM 5 GA. (.209") STRIP APPROX. 30.1" WIDE

DRAWING		LZ 5 - NEW STYLE SHEET	
PROJECT		SHORELINE STEEL SUPPLY, INC.	
SCALE	FULL SIZE	DRAWING DATE	5 DECEMBER 1994
DRAWN BY	J.C.B.	LAST REV. DATE	
GENERAL MARINE SERVICE CORPORATION 22594 ARDMORE PARK DRIVE ST. CLAIR SHORES, MI 48061-2011 586-777-0945			94-1211
			DRAWING NUMBER