

COMPUTED PROPERTIES, AS DESIGNED

AREA PER PILE - 9.559 SQ. IN.  
 AREA PER FOOT OF WALL - 4.295 SQ. IN.  
 LAYING WIDTH - 26.71 IN.  
 WEIGHT PER FOOT OF PILE - 32.532 LBS.  
 WEIGHT PER SQ. FOOT OF WALL - 14.616 LBS.  
 WALL DEPTH - 9.34 IN.  
 MATERIAL THICKNESS - 0.250 IN.  
 MOMENT OF INERTIA PER PILE - 136.870 IN.<sup>4</sup>  
 MOMENT OF INERTIA PER FOOT OF WALL - 61.492 IN.<sup>4</sup>  
 SECTION MODULUS PER PILE - 29.030 IN.<sup>3</sup>  
 SECTION MODULUS PER FOOT OF WALL - 13.042 IN.<sup>3</sup>  
 SHEET SECTION PERIMETER - 76.971 IN.  
 C/G TO OUTER FIBER - Y = 4.715 IN.

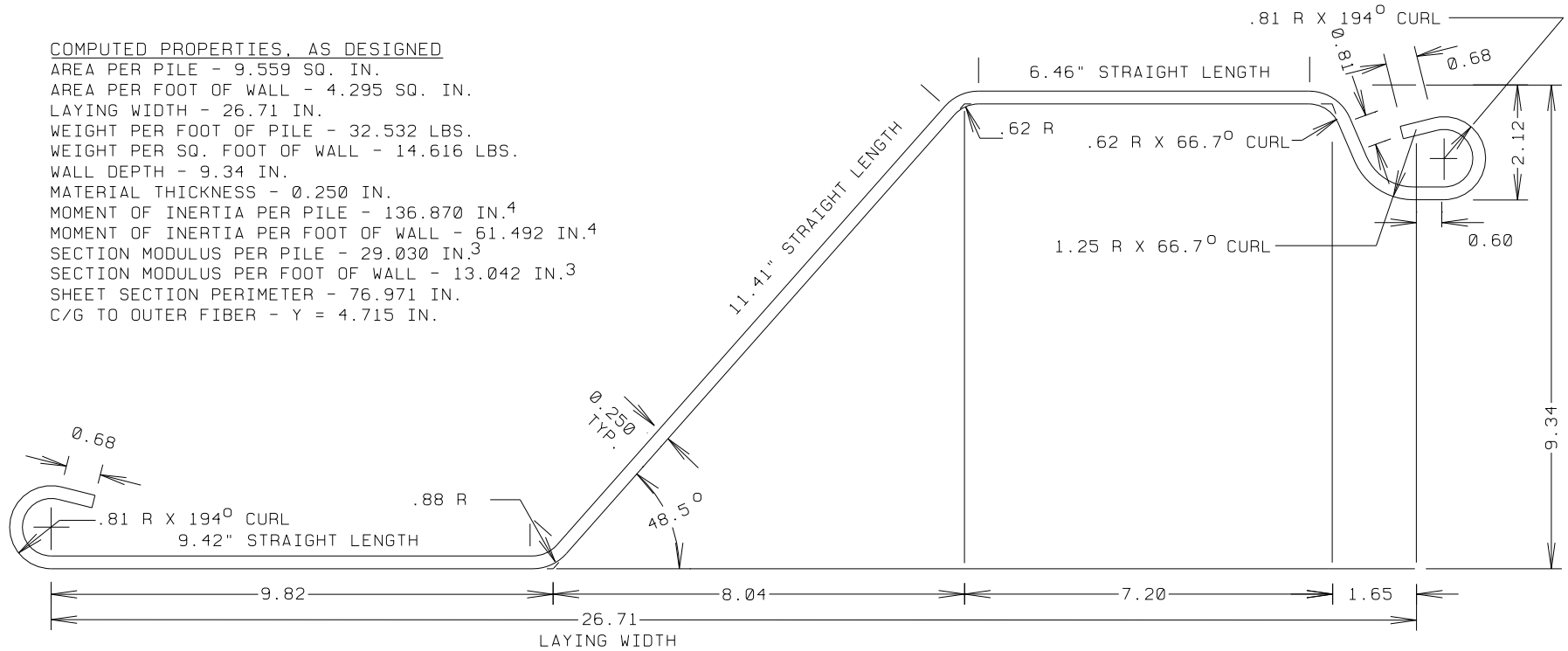

COATING AREA - SQ.FT.PER LIN.FT.OF PILE  
 FOR DIP COATING - 6.41 SQ.FT.  
 FOR SPRAY COATING - 5.93 SQ.FT.

ROLL FROM 1/4" STRIP APPROX. 38.2" WIDE

DRAWING		SZ 14.5 NEW STYLE SHEET	
PROJECT		SHORELINE STEEL SUPPLY, INC.	
SCALE	FULL SIZE	DRAWING DATE	1 DECEMBER 1993
DRAWN BY	J.C.B.	LAST REV. DATE	
GENERAL MARINE SERVICE CORPORATION 22594 ARDMORE PARK DRIVE ST. CLAIR SHORES, MI 48081-2011 586-777-0945			93-1204 DRAWING NUMBER